

**BALDOR® • RELIANCE** 

**Product Information Packet**

**VECP83587T-4**

**2HP,1755RPM,3PH,60HZ,145TC,0535M,TEFC,F1**

Part Detail							
Revision:	AM	Status:	PRD/A	Change #:		Proprietary:	No
Type:	AC	Elec. Spec:	05WG836	CD Diagram:	CD0006	Mfg Plant:	
Mech. Spec:	05F161	Layout:	05LYF161	Poles:	04	Created Date:	11-29-2010
Base:	N	Eff. Date:	01-17-2020	Leads:	3#18		

Specs			
Catalog Number:	VECP83587T-4	Inverter Code:	Inverter Duty
Enclosure:	TEFC	KVA Code:	L
Frame:	145TC	Lifting Lugs:	Standard Lifting Lugs
Frame Material:	Iron	Locked Bearing Indicator:	Locked Bearing
Output @ Frequency:	2.000 HP @ 60 HZ	Motor Lead Quantity/Wire Size:	3 @ 18 AWG
Synchronous Speed @ Frequency:	1800 RPM @ 60 HZ	Motor Lead Exit:	Ko Box
Voltage @ Frequency:	460.0 V @ 60 HZ	Motor Lead Termination:	Ring Terminals
XP Class and Group:	CLI GP A,B,C,D	Motor Type:	0534M
XP Division:	Division II	Mounting Arrangement:	F1
Agency Approvals:	CSA	Power Factor:	77
	CSA EEV	Product Family:	Chem Process S/P 32-8 IEEE 841
	UR	Pulley End Bearing Type:	Ball
Auxillary Box:	No Auxillary Box	Pulley Face Code:	C-Face
Auxillary Box Lead Termination:	None	Pulley Shaft Indicator:	Standard
Base Indicator:	No Mounting	Rodent Screen:	None
Bearing Grease Type:	Polyrex EM (-20F +300F)	RoHS Status:	ROHS COMPLIANT
Blower:	None	Shaft Extension Location:	Pulley End
Constant Torque Speed Range:	1.5	Shaft Ground Indicator:	No Shaft Grounding

<b>Current @ Voltage:</b>	2.700 A @ 460.0 V	<b>Shaft Rotation:</b>	Reversible
<b>Design Code:</b>	B	<b>Shaft Slinger Indicator:</b>	No Slinger
<b>Drip Cover:</b>	Drip Cover	<b>Speed Code:</b>	Single Speed
<b>Duty Rating:</b>	CONT	<b>Motor Standards:</b>	NEMA
<b>Electrically Isolated Bearing:</b>	Not Electrically Isolated	<b>Starting Method:</b>	Direct on line
<b>Feedback Device:</b>	NO FEEDBACK	<b>Thermal Device - Bearing:</b>	None
<b>Front Face Code:</b>	Standard	<b>Thermal Device - Winding:</b>	None
<b>Front Shaft Indicator:</b>	None	<b>Vibration Sensor Indicator:</b>	No Vibration Sensor
<b>Heater Indicator:</b>	No Heater	<b>Winding Thermal 1:</b>	None
<b>Insulation Class:</b>	F	<b>Winding Thermal 2:</b>	None
		<b>XP Temp Code:</b>	T4

<b>Nameplate NP3235E</b>			
<b>CAT.NO.</b>	VECP83587T-4		
<b>SPEC.</b>	05F161W836G1		
<b>HP</b>	2	TE	
<b>VOLTS</b>	460		
<b>AMPS</b>	2.7		
<b>R.P.M.</b>	1755		
<b>FRAME</b>	145TC	<b>HZ</b>	60
<b>SER.F.</b>	1.15	<b>CODE</b>	L
<b>RATING</b>	40C AMB-CONT		
<b>SN</b>			
<b>DE</b>	6205	<b>ODE</b>	6205
<b>NEMA NOM. EFF.</b>	87.5	<b>P.F.</b>	77
<b>GUAR. MIN. EFF.</b>	85.5	<b>CC</b>	010A
<b>T. CODE</b>	T4	<b>TEMP=</b>	135
		<b>IP</b>	56
		<b>PH</b>	3
		<b>CLASS</b>	F

<b>Nameplate NP3186E</b>		
<b>SPEC.</b>	05F161W836G1	
<b>D.E. BRG.</b>	25BC02X30X	
<b>O.D.E. BRG.</b>	25BC02X30X	
<b>GREASE</b>	POLYREX EM	
<b>WEIGHT</b>	67	<b># OF ROTOR BARS</b> 28
<b>RPM MAX</b>	2700	<b>MAX. KVAR</b> .67
<b>BLANK</b>		<b># OF STATOR SLOTS</b> 36
<b>INV.TYPE</b>	PWM	
<b>T=</b>	135	
<b>C HP FR</b>	60	<b>C HP TO</b> 90
<b>CT HZ FROM</b>	1.5	<b>CT HZ TO</b> 60
<b>VT HZ FROM</b>	0-	<b>VT HZ TO</b> 60
<b>HTR-VOLTS</b>	N/A	<b>HTR-AMPS</b> N/A
<b>HTR-WATTS</b>		<b>MAX. SPACE HEATER TEMP.</b> N/A

Parts List		
Part Number	Description	Quantity
SA212730	SA 05F161W836G1	1.000 EA
RA199959	RA 05F161W836G1	1.000 EA
34FN3002B01	EXTERNAL FAN, PLASTIC, .637/.639 HUB W/	1.000 EA
HW3201A05	3/8-16 EYEBOLT	1.000 EA
06CB1001A01G	CONDUIT BOX, MACH GRAY	1.000 EA
RM1016	LEAD SEPARATOR GASKET - 305/306 C.P.MOTO	1.000 EA
51XW2520A12	SCREW, HEX SER SLT HD, ZN, 1/4-20 X .75	2.000 EA
11XW1032G06	10-32 X .38, TAPTITE II, HEX WSHR SLTD U	1.000 EA
HW3001B01	BRASS CUP WASHER, FOR #10 SCREW	1.000 EA
10XN2520S06	1/4 20X3/8 HX HD CAP S.S.	2.000 EA
WD1000B16	T&B CX70TN OR L70P TERMINAL LUG	1.000 EA
51XN1032A20	10-32 X 1 1/4 HX WS SL SR	2.000 EA
05EP1100A03G	FREP TEFC 203,GRSR,RLF,NO DRAIN	1.000 EA
HW4601A22	INPRO SEAL, 205 BRG, VBX	1.000 EA
HW4500A01	1641B(ALEMITE)400 UNIV, GREASE FITT	1.000 EA
HA4051A00	PLASTIC CAP FOR GREASE FITTING	1.000 EA
HW4500A17	317400 ALEMITE GREASE RELIEF	1.000 EA
HW5100A05	WVY WSHR F/205 & 304 BRGS	1.000 EA
35EP1329A33G	EP ENCL,GRSR,RLF,(2).25-28 DRAINS, INPRO	1.000 EA
HW4601A22	INPRO SEAL, 205 BRG, VBX	1.000 EA
HW4500A01	1641B(ALEMITE)400 UNIV, GREASE FITT	1.000 EA
HA4051A00	PLASTIC CAP FOR GREASE FITTING	1.000 EA
HW4500A17	317400 ALEMITE GREASE RELIEF	1.000 EA
HA4010A01	T-DRAIN PLUG,416 S.S.,W/ 1/4-28 THD & .0	2.000 EA

Parts List (continued)		
Part Number	Description	Quantity
51XN1032A20	10-32 X 1 1/4 HX WS SL SR	2.000 EA
HA3100A28	THRUBOLT 10-32 X 8.187	4.000 EA
51XB1214A16	12-14X1.00 HXWSSLD SERTYB	1.000 EA
35FH1000A27G	35FH1000A27 W/GRAY FLUIDIZ	1.000 EA
10XN2520A16	1/4-20 X 1 HEX HEAD CAP SCR, ZINC PLATED	3.000 EA
HW1001A25	LOCKWASHER 1/4, ZINC PLT .493 OD, .255 I	3.000 EA
35FH4500A01	DRIP COVER, STAMPED X - W/PRIMED	1.000 EA
HA2001A13	35-10103 SPACER WELKER	3.000 EA
51XN1032A20	10-32 X 1 1/4 HX WS SL SR	3.000 EA
WD4100A03	DE-750 HEYCO PLUG 62MP0750 MICRO PLASTIC	1.000 EA
06CB1503A01G	LIPPED CONDUIT BOX LID, MACH GRAY EPOXY	1.000 EA
06GS1009	GASKET, KOBX LID, 1/8" THICK BLACK NEOPR	1.000 EA
10XN2520A12	1/4-20 X 3/4 HEX HEAD CAP	2.000 EA
HW1001A25	LOCKWASHER 1/4, ZINC PLT .493 OD, .255 I	2.000 EA
HW2501D13	KEY, 3/16 SQ X 1.375	1.000 EA
HA7000A01	KEY RETAINER 7/8" DIA SHAFT	1.000 EA
MJ5004A59	ADHESIVE LOCTITE #401 SURFACE INSENSITIV	0.010 EA
MJ5001A27	32220KN GRAY SEALER *MIN BUY 4 QTS=1GAL	0.001 QT
MJ1000A73	INPRO P-80 ASSEMBLY LUB./ 1 QT. CONTAIN	0.001 QT
85XU0407S04	4X1/4 U DRIVE PIN STAINLESS	4.000 EA
LB1115N	LABEL,LIFTING DEVICE (ON ROLLS)	1.000 EA
LT0019A00	MOTOR NO-LOAD PERFORMANCE DATA SHEET	1.000 EA
WD1000D21	TRM,T&B #B71M,RING,18-14,.25,NON-INSL	3.000 EA
MJ1000A02	GREASE, MOBIL POLYREX EM - 124047	0.050 LB

Product Information Packet: VECP83587T-4 - 2HP,1755RPM,3PH,60HZ,145TC,0535M,TEFC,F1

MG1025N19	WILKOFAST, 778.50, RELIANCE BLUE-GREEN	0.010 GA
LB1119N	WARNING LABEL	1.000 EA
LC0006	CONNECTION LABEL	1.000 EA
LB1449	DIV-2/NEC WARNING LABEL	1.000 EA
NP3235E	SS IEEE841 DIV-2 UL CSA-C US EEV PREM	1.000 EA
NP3186E	SS IEEE841 INV AUX DATA INFORMATION	1.000 EA
36PA1001	PKG GRP, PRINT PK1017A06	1.000 EA
PK3082	STYROFOAM CRADLE	1.000 EA
MN416A01	TAG-INSTAL-MAINT no wire (1200/bx) 3/19	1.000 EA

**AC Induction Motor Performance Data**

Record # 47105 - Typical performance - not guaranteed values

<b>Winding:</b> 05WGW836-R056	<b>Type:</b> 0534M	<b>Enclosure:</b> TEFC
-------------------------------	--------------------	------------------------

Nameplate Data				460 V, 60 Hz: Single Voltage Motor	
Rated Output (HP)	2			Full Load Torque	6 LB-FT
Volts	460			Start Configuration	direct on line
Full Load Amps	2.7			Breakdown Torque	23.47 LB-FT
R.P.M.	1755			Pull-up Torque	13.29 LB-FT
Hz	60	Phase	3	Locked-rotor Torque	15.83 LB-FT
NEMA Design Code	B	KVA Code	L	Starting Current	22.65 A
Service Factor (S.F.)	1.15			No-load Current	1.49 A
NEMA Nom. Eff.	87.5	Power Factor	77	Line-line Res. @ 25°C	6.28 Ω
Rating - Duty	40C AMB-CONT			Temp. Rise @ Rated Load	40°C
S.F. Amps				Temp. Rise @ S.F. Load	48°C
				Locked-rotor Power Factor	46.5
				Rotor inertia	0.201 LB-FT <sup>2</sup>

Load Characteristics 460 V, 60 Hz, 2 HP

% of Rated Load	25	50	75	100	125	150	S.F.
Power Factor	36	58	70	78	82	85	78
Efficiency	81.3	87.8	89	88.3	87.8	86.5	88.1
Speed	1788	1779	1768	1752	1744	1730	1748
Line amperes	1.59	1.87	2.26	2.73	3.25	3.82	3.14

Performance Graph at 460V, 60Hz, 2.0HP Typical performance - Not guaranteed values

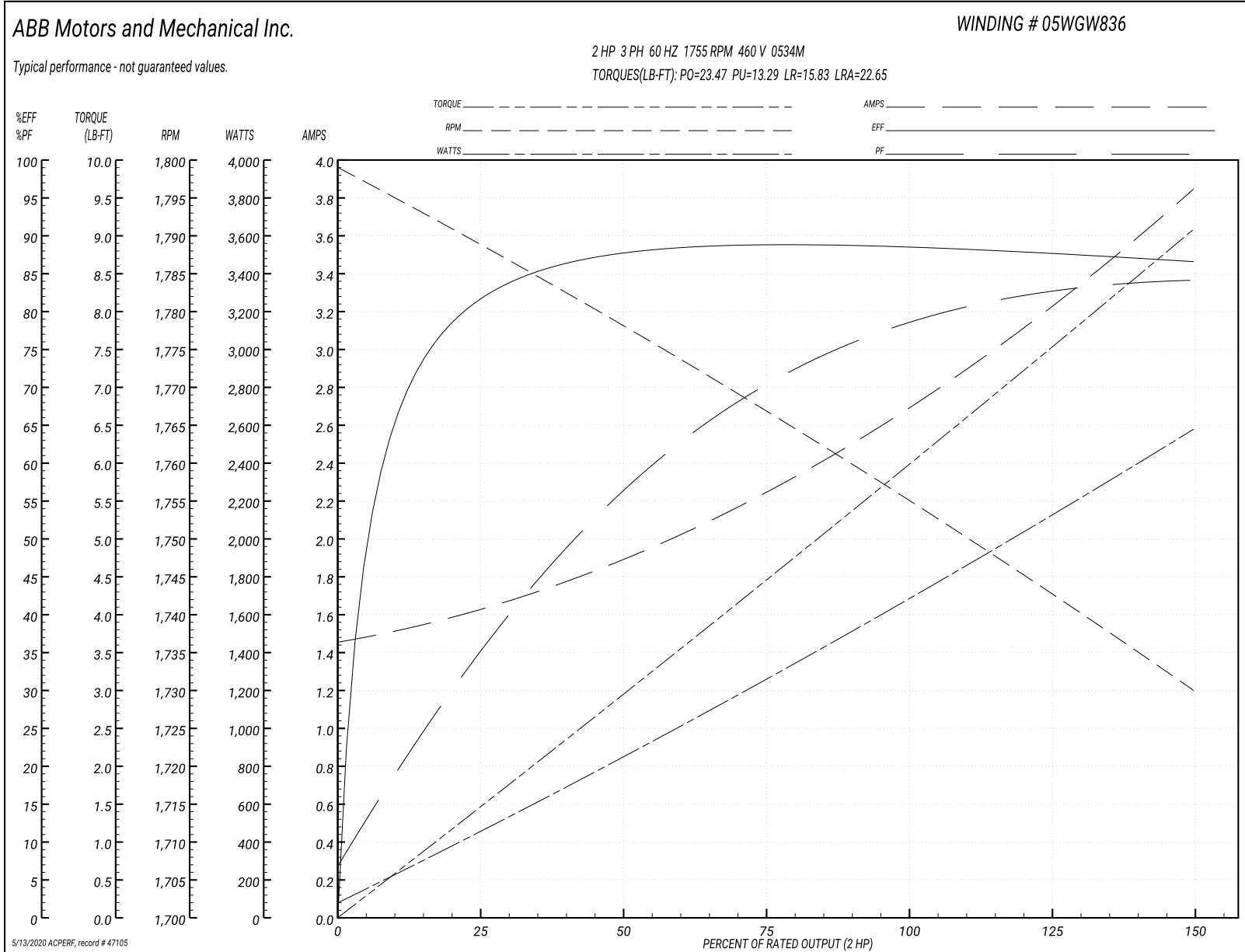

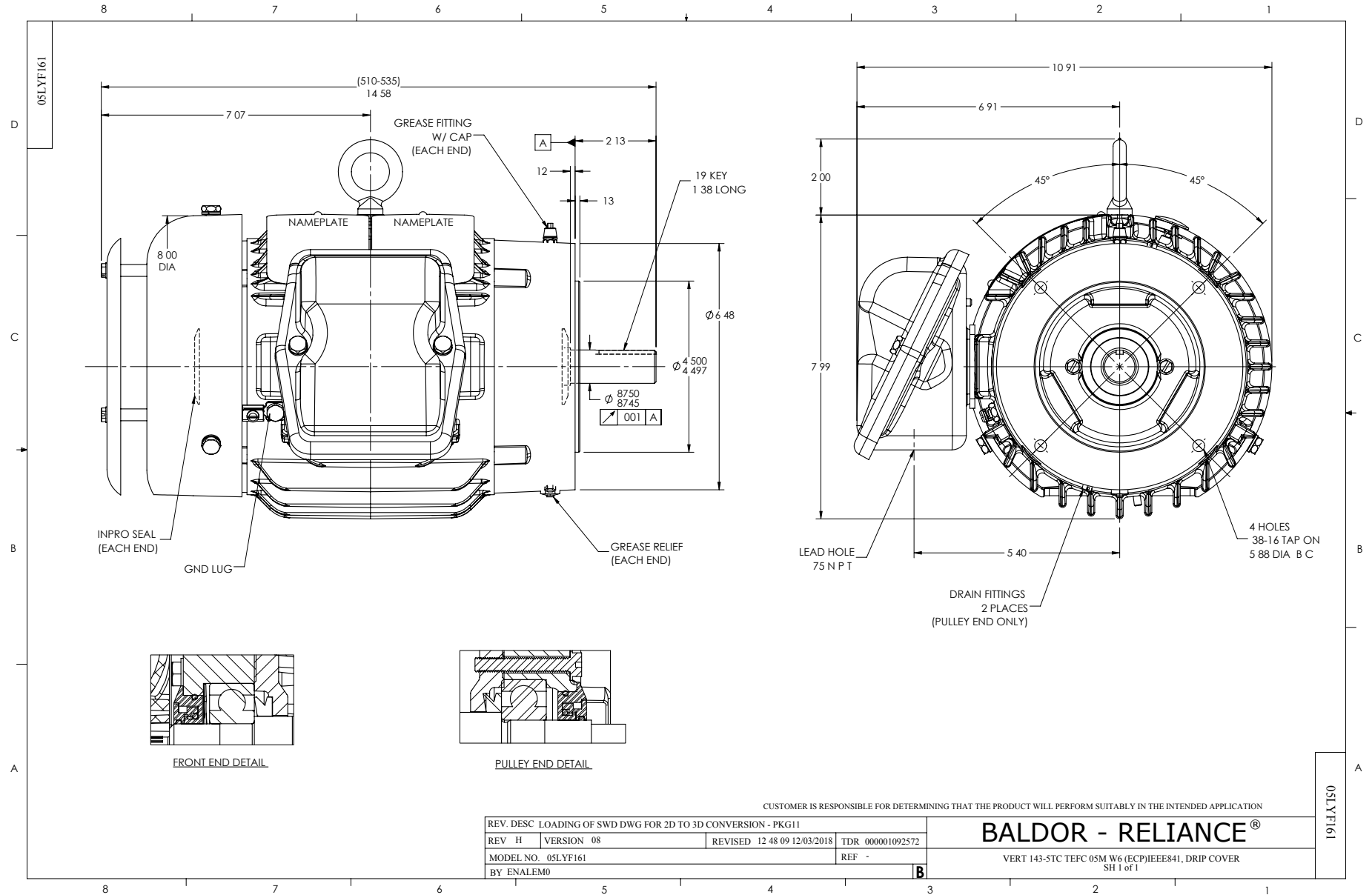

CD0006

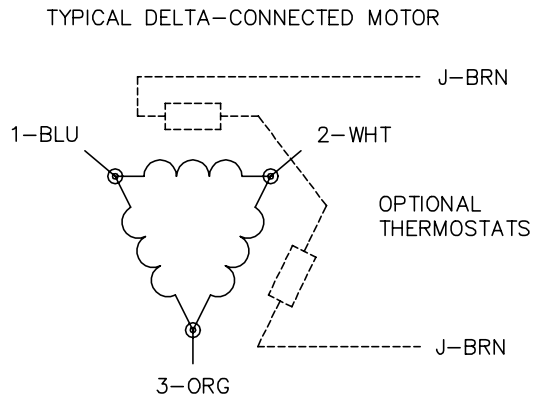
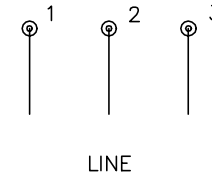
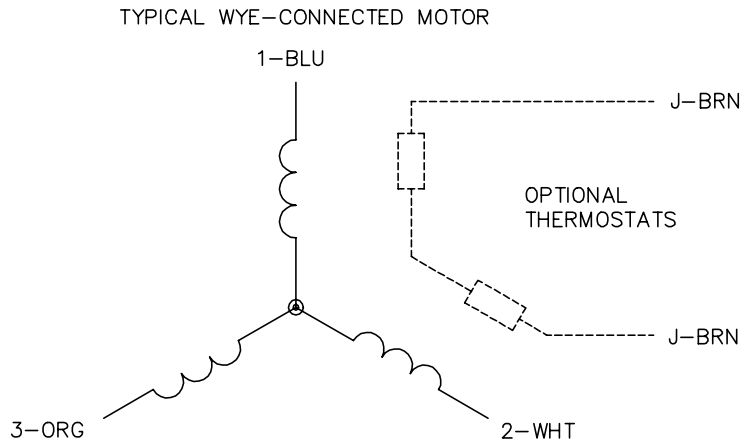

NOTES:

1. THREE LEAD MOTOR MAY BE EITHER WYE CONNECTED OR DELTA CONNECTED.
2. INTERCHANGE ANY TWO LINE LEADS TO REVERSE ROTATION.
3. OPTIONAL THERMOSTATS ARE PROVIDED WHEN SPECIFIED.
4. ACTUAL NUMBER OF INTERNAL PARALLEL CIRCUITS MAY VARY.
5. LEAD COLORS ARE OPTIONAL. LEADS MUST BE NUMBERED AS SHOWN.

CD0006

REV. DESC: ADD CLASS CONN00000007		
REV. LTR: E	VERSION: 01	TDR: 000001099922
FILE: \AAA\00005\141	REVISED: 10:24:49 02/19/2019	BY: ENBRIRO
MTL: -		

**BALDOR - RELIANCE®**

3PH, SV, 3 LEADS, WYE OR DELTA CONNECTED

SH 1 of 1